

Eicher Pro 5025T
The 25 Ton GVW Tipper

TRUCKS

MOVE AHEAD!



 **EICHER** GO PRO

PARTNERSHIP WITH THE VOLVO GROUP

Two leading players in the commercial vehicle business joined hands in 2008 with a convergent vision of driving modernization in commercial transportation. Volvo Group, the world's leading manufacturers of trucks, buses, construction equipment and marine & industrial engines, bought its global expertise and world class technology, while Eicher Motors brought its frugal engineering and deep knowledge of the developing markets.

The mission of this joint venture- VE Commercial Vehicles Ltd. raising the standard of the commercial transportation industry and taking it to new professional level.



Leader in commercial transportation

Frugal engineering and operation

Aftersales infrastructure

Cost-effective operations

VOLVO

VOLVO GROUP

Global expertise

Leadership in product technology

Well-defined processes and control

Brand image



GLOBAL TECHNOLOGY MEETS FRUGAL ENGINEERING

The completely new chassis and assembly line have been built to balance high technology with frugal engineering. The state-of-the-art manufacturing process which includes a robotic cab weld shop, CED paint shop and 100% hot test facility, ensures quality and reliability of international standards.

GLOBAL STANDARD MANUFACTURING PLANT

The Eicher Pro series has been designed and developed in a modern and high-tech manufacturing facility in Pithampur, near Indore.

The next-generation engine plant, built in collaboration with the Volvo Group, not only manufactures Euro III and IV heavy-duty engines but also supplies Euro VI engines internationally to the Volvo Group.



EICHER PRO 5000 SERIES

Eicher Pro 5000 series is a new range of highly durable and reliable BSIII trucks from 16T to 40T GVW which cater to the needs of the growing commercial vehicle industry across different segments. These trucks are designed to deliver best-in-class fuel efficiency, optimised operational cost, leading to quick returns on investment.



Best-in-class Fuel Efficiency



Enhanced Reliability and Durability



Low Maintenance Cost



Lifetime Support Solutions



Higher Payload

KEY FEATURES



- Modern and spacious cabin with state-of-the-art features
- 6-way adjustable driver seat for comfortable drives
- CED painted cabin with high-gloss life
- Fans in cabin for driver and co-driver comfort
- Dual footstep with grab handle for easy climbing
- Refreshed dashboard with lockable and open storage spaces and 3 din system
- Tilt and telescopic power steering



Instrument cluster with LCD display

OTHER FEATURES



- World-class cummins engine with 180 HP & 685 Nm torque
- Enhanced reliability
- Better pickup & faster turnaround time



- Globally-preferred meritor axle
- Enhanced durability & reliability



- ZF 9-Speed gearbox
- Higher durability



- Heavy-duty bogie suspension
- Enhanced suspension life with 11 leaves

Move ahead in your trucking business with Eicher Pro 5025T having competitive fuel efficiency backed by Volvo group's expertise, Eicher enhanced lifetime support solutions and a contemporary cabin for superior ride comfort to boost driver efficiency. Move ahead with Eicher, Move ahead for more.



LIFETIME SUPPORT SOLUTIONS

PARTNERING PROSPERITY

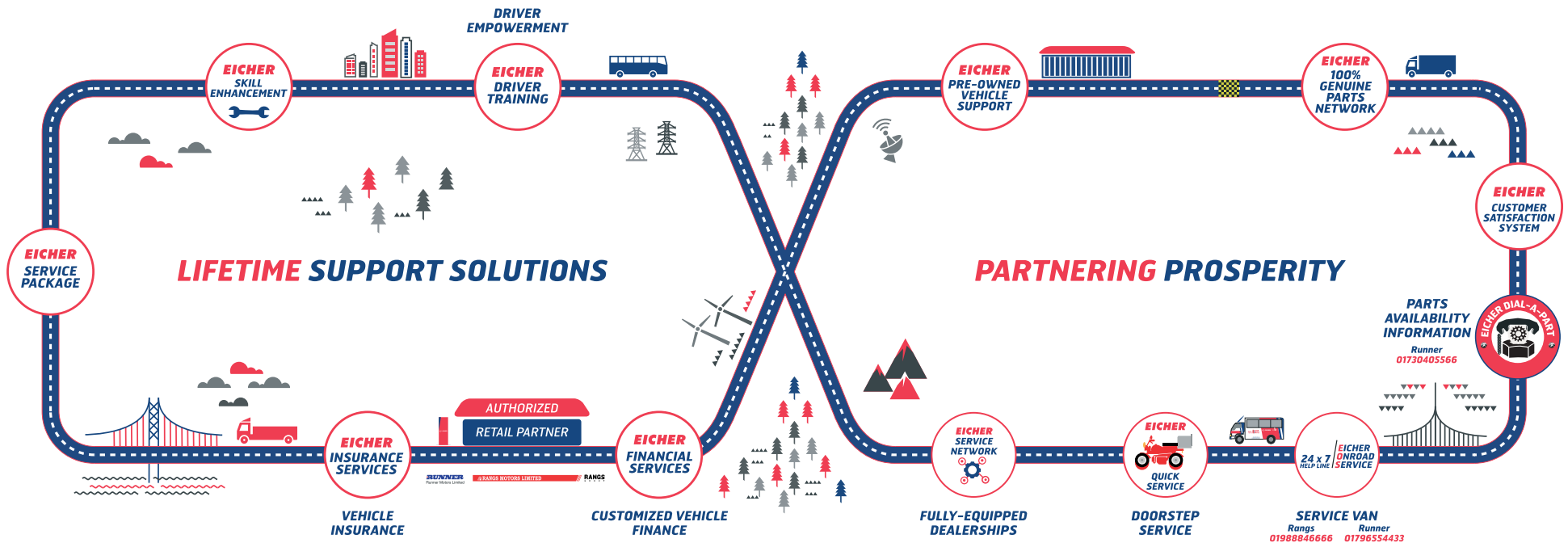

TECHNICAL SPECIFICATION

SPECIFICATIONS

Eicher Pro 5025T

GVW	25000 Kgs.
Engine	5883 cc
Max. power	180Hp @ 2500 rpm
Max. torque	685 Nm @ 1500 rpm
Clutch type	Coil spring push type with Booster assisted
Clutch dia.	380 mm
Gear Box	ZF 1110TD (8 Forward, 1 Crawler & 1 Reverse) with Cable operated gear shifting mechanism.
Gear Ratio	1st (Crawler): 12.73, Reverse: 12.04
Rear Axle	Maritor makes Banjo type Axle
Rear Axle Ratio /FDR	6.833
Front Axle	Reverse Elliot type I Beam
Chassis Type	Rolled C-Channel Straight Frame, 285x76x7 mm
Service Brakes	Dual circuit, full S-cam Air
Suspension Front	Semi-elliptical leaf spring w/o Anti-roll Bar
Suspension Rear	Hendricsons Bogie suspension with 11 leaves (27mm)

Cabin	Hydraulic Tilt-able Sleeper Cabin
Steering	Tilt and Telescopic Power Steering
Gradeability	43%
Max Speed	70 KMPH
Fuel Tank	220 Ltr.
Electrical System	24 V
Battery	150 Amp.
Tyre Size	Front - Std. 10x20-16PR (Rib Pattern) Rear & Spare - Std. 10x20-16PR (Lug Pattern)
Wheel Rim size	7.5x20
TCD	15.8 m
Ground clearance	252 mm
Wheel base	4000 mm
Body	Size 16 Cum Dimension (mm) 4580x2330x1350 Sheet Thickness Floor 6mm, Side Wall & Canopy Tailgate 4mm,
ULW	12260Kgs

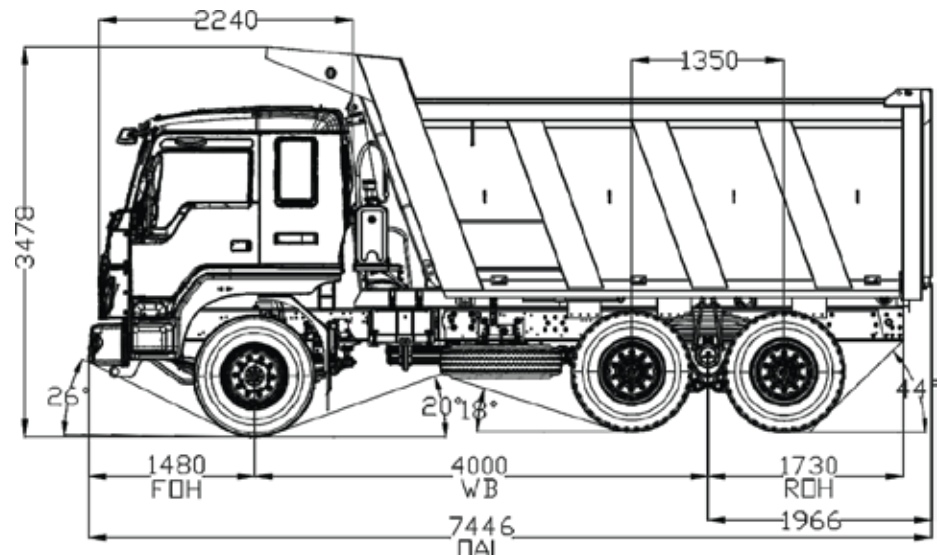
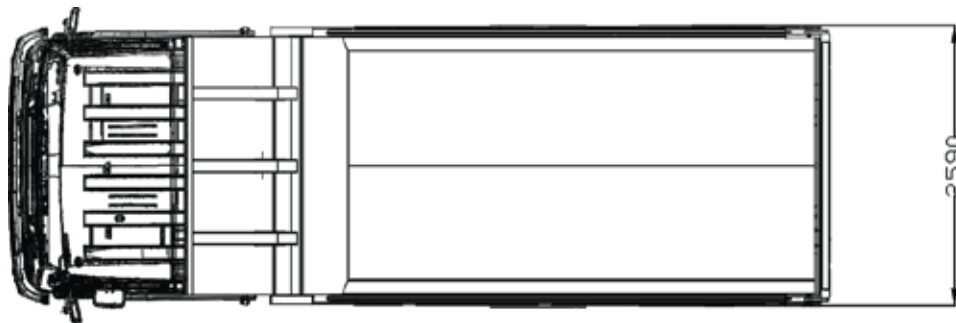



Sale query

01730 406484



Easy spare parts
availability

01730 405566



Eicher mobile
service van

01796 554433

EICHER TRUCKS AND BUSES

VE Commercial Vehicles Ltd.
96, Institutional Area,
3rd Floor, Sector 32
Gurgaon-122001, Haryana.



Authorized Distributor:

RUNNER
motors limited

138/1, Tejgaon I/A, Dhaka-1208, Bangladesh
E mail: rmlsales@runnerbd.com; Web: www.runnerbd.com/motors